

RIPPERS

Professional quality in technology and durability



www.ecoroadsgroup.com

- **Loosens the surface**
- **Brings larger rocks to the surface**
- **3-point linkage**
- **Enables the use of existing material**
- **Use as deep ripper down to 75 cm**

Incredibly powerful, rippers with a hydraulic lifter has seven tine with removable excavator teeth can be used to break up road surface or compacted soil to a depth up to 60cm (23.6")



Spiral spring-loaded tine protection



Comfortably positioned tool box as a standard

- With the special shape of the tines and unique spiral spring-loaded tine protection, the rocks are brought to the surface upon ripping
- Easily exchangeable wear-parts, highest quality standards for supply parts and unbeatable know-how help you to easily manage the most difficult operations and offer highest service with a revolutionary technical concept

Cutting like a knife through butter

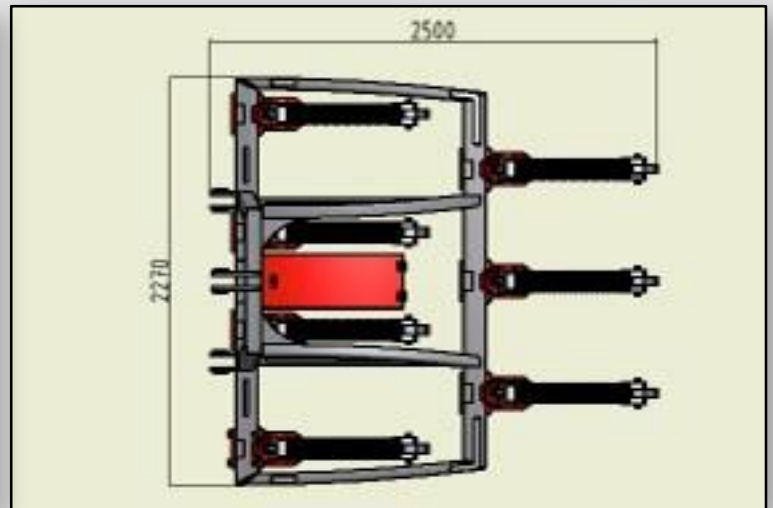
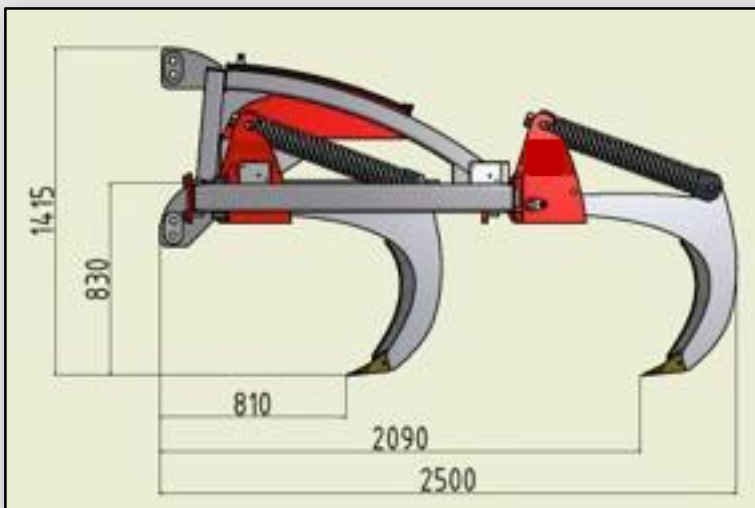

Technical Data

Rippers

Length	2,500 mm
Width	2,300 mm
Number of tines	7
Deadweight	1,600 kg
Working depth	600 mm



products

GRADER



CRUSHER



RIPPERS



COMPACTOR



TERRAROADS INTERNATIONAL, INC

Tel. 1-800-820-9971

contact@ecoroadsgroup.com

www.ecoroadsgroup.com